**User's
Manual**

**Model 701924
PBDH1000 Differential Probe**

Thank you for purchasing the PBDH1000 Differential Probe (Model 701924). This user's manual contains useful information about the functions and operating procedures of the PBDH1000 Differential Probe and lists the handling precautions of the instrument. To ensure correct use, please read this manual thoroughly before beginning operation. After reading this manual, keep it in a convenient location for quick reference in the event a question arises during operation.

Revisions

1st Edition: February 2008

2nd Edition: March 2008

3rd Edition: April 2009

The following safety markings are used in this manual.



Improper handling or use can lead to injury to the user or damage to the instrument. This symbol appears on the instrument to indicate that the user must refer to the user's manual for special instructions. The same symbol appears in the corresponding place in the user's manual to identify those instructions. In the manual, the symbol is used in conjunction with the word "WARNING" or "CAUTION."

WARNING

Calls attention to actions or conditions that could cause serious injury or death to the user, and precautions that can be taken to prevent such occurrences.

CAUTION

Calls attentions to actions or conditions that could cause light injury to the user or damage to the instrument or the user's data, and precautions that can be taken to prevent such occurrences.

Note

Calls attention to information that is important for proper operation of the instrument.

Checking the Contents of the Package

The following accessories are included. If some of the contents are not correct or missing or if there is physical damage, contact the dealer that you purchased them from.

- User's manual (this manual): 1
- Carrying case: 1
- PBDH1000: 1
- Attachments: 1 set

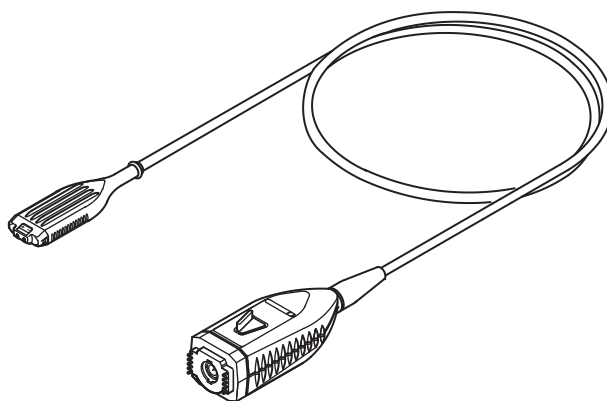

Attachments

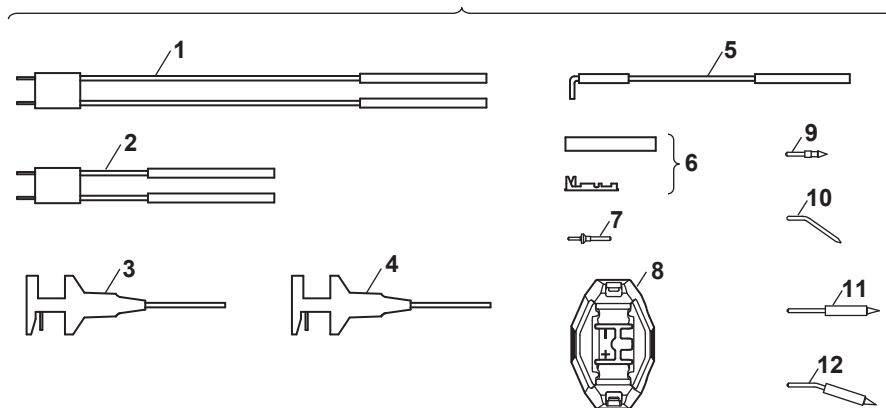

	Name	Quantity
1	10-cm pair leads ¹	2
2	5-cm pair leads ¹	2
3	Red micro clip	1
4	Black micro clip	2
5	6-cm ground extension lead	2
6	Contact, heat-shrink tube ^{1, 2}	1 pack (10 pieces)
7	Flanged input pin ²	10
8	Retaining cover ²	2
9	Straight pin	4
10	Angled pin	4
11	Spring-type straight pin	4
12	Spring-type angled pin	4
1	Connectable to a 0.64-mm square pin (recommended compatible pin diameter: 0.65 mm)	
2	Extension lead kit	

Optional Accessories (Sold Separately)

Part Name	Part Number	Quantity
Ground extension lead	B8099KQ	5
5-cm pair leads	B8099KV	5
10-cm pair leads	B8099KU	5
Black micro clip	B9852VX	1 pack (10 pieces)
Red micro clip	B9852VY	1 pack (8 pieces)
Straight pin	B8099DL	10
Angled pin	B8099DM	10
Spring-type straight pin	B8099DJ	5
Spring-type angled pin	B8099DK	5
Flanged input pin	B8099KX	5
Retaining cover	B8099KY	2
Contact, heat-shrink tube	B8099KW	1 pack (10 pieces)

Safety Symbols and Precautions

To ensure safe and correct operation of the instrument, you must take the safety precautions given on the next page. The instrument may not function if used in a manner not described in this manual. Yokogawa bears no responsibility for, nor implies any warranty against damages occurring as a result of failure to take these precautions.

The following safety symbols and words are used in this manual.



Warning: Handle with care. Refer to the user's manual. This symbol appears on dangerous locations on the instrument which require special instructions for proper handling or use. The same symbol appears in the corresponding place in the manual to identify those instructions.)

See below for operating environmental limitations.

CAUTION

This product is a Class A (for industrial environments) product. Operation of this product in a residential area may cause radio interference in which case the user will be required to correct the interference.

Waste Electrical and Electronic Equipment



Waste Electrical and Electronic Equipment (WEEE), Directive 2002/96/EC

(This directive is only valid in the EU.)

This product complies with the WEEE Directive (2002/96/EC) marking requirement. This marking indicates that you must not discard this electrical/electronic product in domestic household waste.

Product Category

With reference to the equipment types in the WEEE directive Annex 1, this product is classified as a "Monitoring and Control instrumentation" product.

Do not dispose in domestic household waste. When disposing products in the EU, contact your local Yokogawa Europe B. V. office.

Safety Precautions

For safe use of the instrument, and for best results, please heed the following warnings and cautions.



WARNING

- Take care to avoid electric shock when connecting the probe to the circuit under test.
- Never disconnect the probe from the measuring instrument while the probe is connected to the circuit under test.
- Never use the probe with wet hands, or when the probe itself is wet. Electric shock can result.
- Before connecting the probe input terminal to the circuit under test, check that the measuring instrument is properly grounded, and that the probe output connector is connected to the input connector of the oscilloscope.
- Ground the measuring instrument.
Always connect the main instrument's protective grounding.
- Observe the maximum non-destructive input voltage.
Do not apply a voltage that exceeds the following values between the input and ground.
Instantaneous: ± 100 V
Continuous: ± 35 V (DC + AC_{peak})
- Do not use the probe in humid locations
To avoid electric shock, never use the probe in areas of high humidity.
- Do not use the probe near flammable gases.
To avoid injury and fire, do not use the probe near flammable or explosive gasses or vapors.
- Avoid exposed circuits.
To prevent injury, when the power is ON, do not touch any exposed contact points or components.



CAUTION

- The probe head has undergone a precision assembly process. Take sufficient care when handling the probe as sudden changes in ambient temperature and physical shocks can damage it.
 - Do not inadvertently twist or pull the cable. The wires inside the cable can break, causing malfunction.
 - Avoid vibration, shock, and static electricity during shipping and handling. Take extra care not to drop the probe.
 - Avoid storing or using the probe in direct sunlight, or in areas with high temperature, humidity, or condensation. Deformation and deterioration of insulation can occur resulting in failure to retain product specifications.
 - Inspect the probe before use to ensure that damage has not occurred during shipping and storing. If damage is found, contact your nearest Yokogawa dealer or sales representative.
 - This probe is not water or dust resistant. Do not use the probe in areas with a lot of dust, or near water.
-

Contents

Checking the Contents of the Package.....	iii
Safety Symbols and Precautions	v
Safety Precautions.....	vi
Product Overview.....	1
Component Names	2
Usage Precautions.....	3
Operating Procedures.....	3
Product Specifications	11
Appendix 1 Frequency Characteristics of Each Attachment.....	App-1
Appendix 2 Input Equivalent Circuit and DC Voltage Accuracy.....	App-4
Appendix 3 Probing	App-5

Product Overview

The PBDH1000 Differential Probe is a 1-GHz bandwidth, differential-input, active probe that is used in combination with a digital oscilloscope that has a YOKOGAWA probe interface (hereafter referred as digital oscilloscope with a probe interface).

To use the probe, you simply connect it to a BNC input terminal on a digital oscilloscope with a probe interface.

* For information about digital oscilloscopes with a probe interface, contact your nearest YOKOGAWA dealer.

Features

- Allows direct observation of differential signals
- Common mode rejection capability
- Wide frequency bandwidth from DC to 1 GHz
- High input impedance (1 M Ω , approx. 1.1 pF between each input terminal and ground)
- Able to receive power from a digital oscilloscope with a probe interface
- Allows a digital oscilloscope with a probe interface to automatically detect the probe*
- Comes with various attachments that can be changed according to the item that you want to measure
- Compact and lightweight

* For a DL9000 Series digital oscilloscope to automatically detect this probe, the DL9000 firmware version must be 4.05 or later.

Component Names

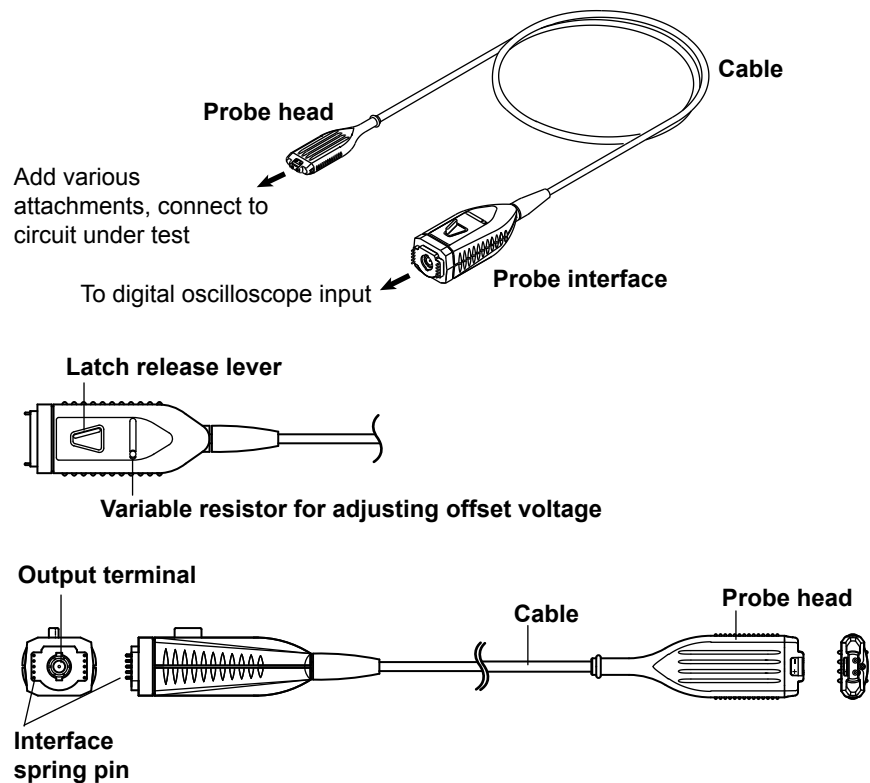

Probe interface

Connects to a digital oscilloscope input.

Interface spring pins

When the probe output terminal is connected, these pins touch the pad on the oscilloscope interface board. The probe's power is supplied through these interface pins. The interface pins are also used to supply a offset voltage and used by the DL9000 to automatically detect the probe.

Cable

Connects the probe interface and the probe head.

Probe head

Connect various attachments to the signal input terminals, and then connect to the item you want to measure.

Latch release lever

Releases the lock connecting the probe output terminal to the oscilloscope input.

Output terminal

The output terminal is a BNC connector. It connects to an oscilloscope input BNC connector.

Variable resistor for adjusting offset voltage

You can adjust the offset voltage using an appropriate driver as described below.

Adjustment driver

Use an adjustment driver that fits into the adjustment groove. Using a driver with a large grip or a driver with a small head can damage the adjustment turn stop or groove.

Recommended adjustment driver bit dimensions

Head thickness (W): 0.2 to 0.35 mm; head width (L): 1.3 to 1.5 mm; head shape: flat or Philips

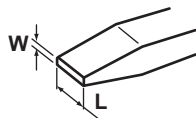

Usage Precautions

CAUTION

Use a soft cloth to wipe away dirt, and be careful not to damage the probe.
Do not immerse the probe in liquid or use abrasive cleaners on the probe.
Do not use any volatile solvents such as benzene.

Do not bring the probe near transformers, circuits with large currents, wireless devices, or other objects emitting large electric or magnetic fields. Doing so may produce inaccurate measurement results.

Operating Procedures

Preparation

1. Have the probe and a digital oscilloscope with a probe interface ready.
2. Insert the probe interface completely into the oscilloscope input, and confirm that the BNC connector and interface pin are securely fastened. You will hear the latch click when the connectors lock into place.
3. When you connect the probe to a digital oscilloscope with a probe interface, the probe's attenuation ratio and input coupling are set automatically.*
 - * For a DL9000 Series digital oscilloscope to automatically detect this probe, the DL9000 firmware version must be 4.05 or later.
4. Attach any of the provided attachments or attachments that you constructed to the probe head signal input terminals.

Note

If you are connecting the probe to a DL9000 Series digital oscilloscope with software version earlier than 4.05, manually configure the following settings after you connect it. For information on how to update the DL9000 Series software, contact your nearest YOKOGAWA dealer.

- Set the probe attenuation ratio to 50:1.
 - Set the input coupling to 50 Ω .
-

Attachment Handling

Connect attachments that are suitable for the item that you want to measure to the signal input terminals illustrated below. Select attachments from the following list (see page 9 for attachment application examples).

- 5-cm pair lead
Can connect directly to a pin header or the item you want to measure. It includes a damping resistor that takes pin header connection into account.
- 10-cm pair lead
Used in combination with a micro clip. It includes a damping resistor that takes the micro clip into account. It is suitable for measuring relatively low-frequency signals.
- Pin
The following four types are available. They are suitable for measuring relatively high-frequency signals.
 - Straight pin
 - Angled pin
 - Spring-type straight pin
 - Spring-type angled pin
- A lead that you created using a kit
Create your own lead when you need a lead that is longer than the ones included in the accessories, or when you want to prevent the lead from coming loose from the probe head by using the retaining cover. For instructions on how to create your own lead, see the next page.

Note

- The provided pair leads include the following damping resistors. These pair leads can connect to a 0.64-mm square pin.
 - 5-cm pair lead: 100 Ω , 1/4 W, 1%
 - 10-cm pair lead: 150 Ω , 1/4 W, 1%
- For typical frequency characteristics of attachments, see appendix 1.

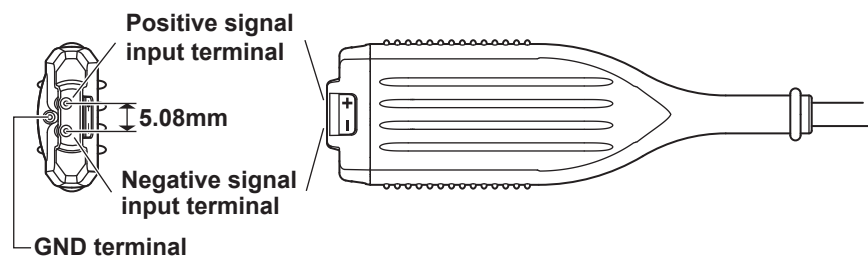

Because the probe input is high impedance, the inductance from the probe head to the circuit under test has a large effect on the measured results of high frequency signal components. When measuring signals that include frequency components of 100 MHz or higher, we recommend that you use the shortest attachments possible for both the positive and negative input terminals.

Creating an Extension Lead

You can create your own extension lead using the accessory kit.

At the Circuit-under-Test End

1. Pass the lead wire through a heat-shrink tube for a contact.
2. Crimp or solder the lead wire's core wire to the contact.
3. Cover the contact with the heat-shrink tube, and then apply heat with a drier to fix the tube in place.

In step 2, you can insert a damping resistor between the lead wire and contact as shown in the illustration below on the right.

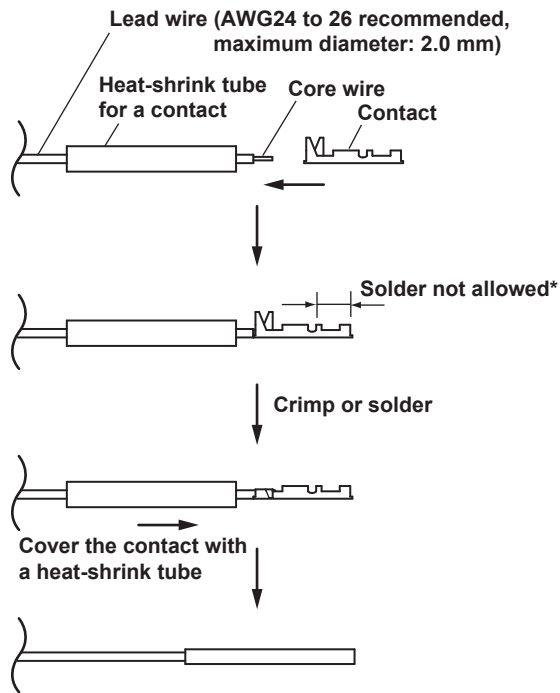

<When inserting a resistor>

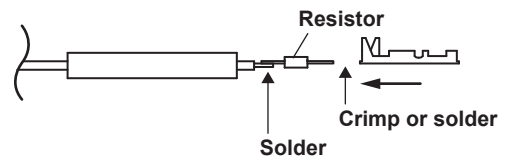

Examples of resistances that you can insert (when using a micro clip)

Lead Wire Length	Resistance
5 cm	150Ω
10 cm	150Ω
20 cm	180Ω

* If solder gets into this section, the contact or the circuit under test may break.

Note

A dedicated crimping tool is needed to crimp the lead wires (SST-017 by Stack Electronics Co, Ltd.).

Probe-Head End

4. Pass the lead wire through the heat-shrink tube.
 - * The heat-shrink tube for the probe-head end is not included. It must be obtained separately.
5. Solder the lead wire's core wire to the flanged input pin.
6. Cover the flanged input pin with a heat-shrink tube, and then apply heat with a drier to fix the tube in place.

Do not cover the section of the flanged input pin to the left of the broken lines shown in the following figure with the heat-shrink tube. Make sure that the diameter of the tube after shrinking is 2.0 mm or less. If the maximum diameter exceeds 2.0 mm, the lead wire will not be able to pass through the retaining cover.

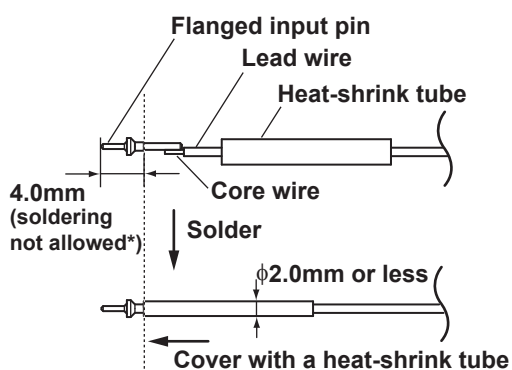

* If solder gets on this section (4 mm from the tip), the probe may break.

Attaching the Retaining Cover

7. Pass the flanged sections of the two input pins through the center retaining-cover holes, and place the input pins on the holders on either side.

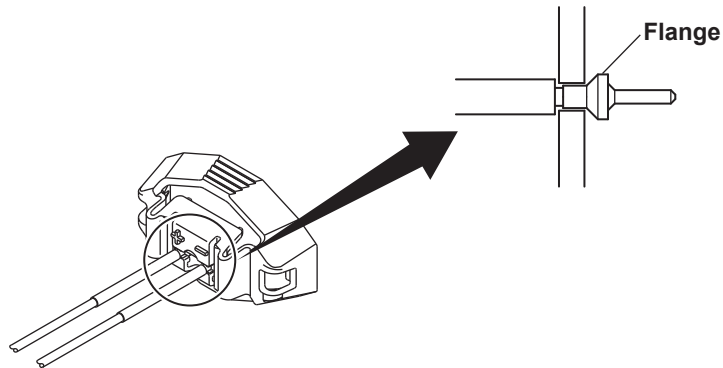

8. Align the + and - markings on the retaining cover to those on the probe head, and attach the retaining cover to the probe head. Check that the retaining cover's left and right latches are securely locked.

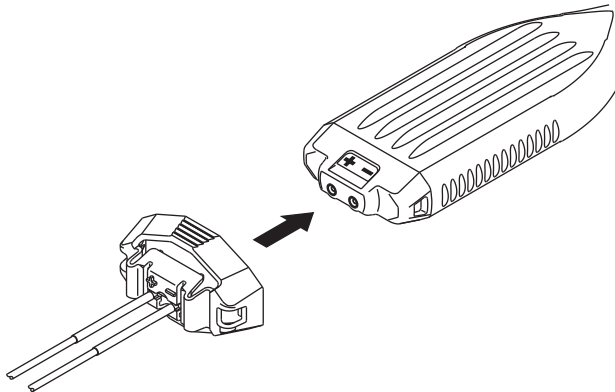

Removing the Retaining Cover

9. While pinching the retaining cover at the top and bottom, remove the cover from the probe head.

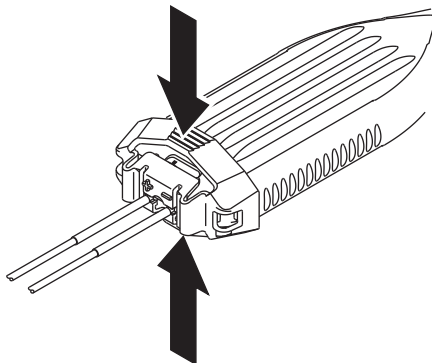

Note

- The retaining cover can only be used with a flanged input pin that is included in the package.
- You cannot use the probe's ground terminal if you use the retaining cover.

How to Use the Ground Extension Lead

Example

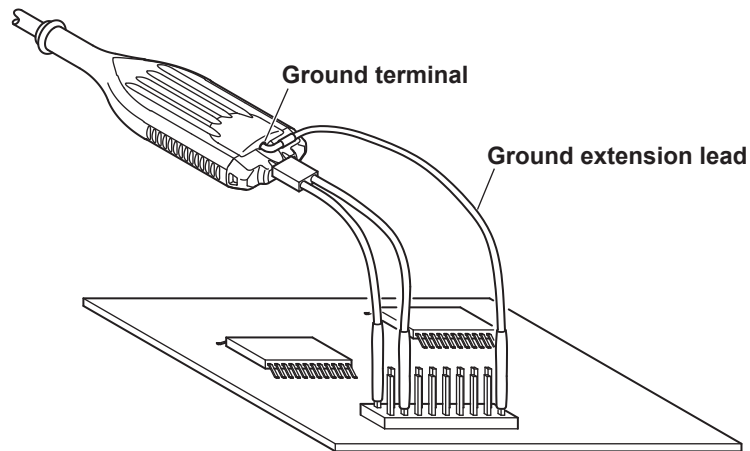

Connecting the probe ground terminal to the common ground on the circuit under test using the ground extension lead may reduce noise when measuring low-frequency signals.



CAUTION

Only connect the ground extension lead to the common ground. If you are measuring a floating circuit, do not use the ground terminal. Doing so may damage the measuring system or the circuit under test.

Example

10-cm pair lead with micro chip

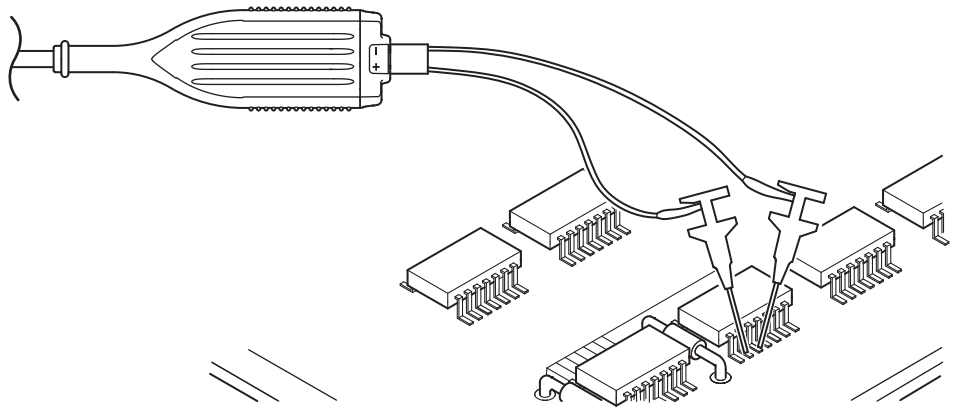

5-cm pair lead

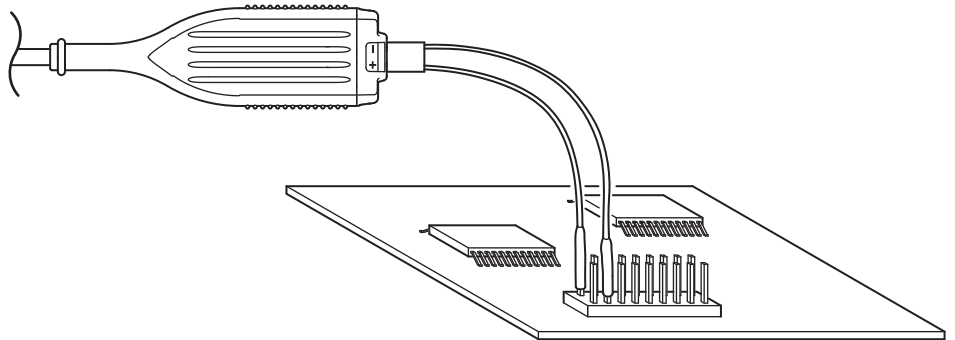

Pin (straight, angled, spring-type straight or angled)

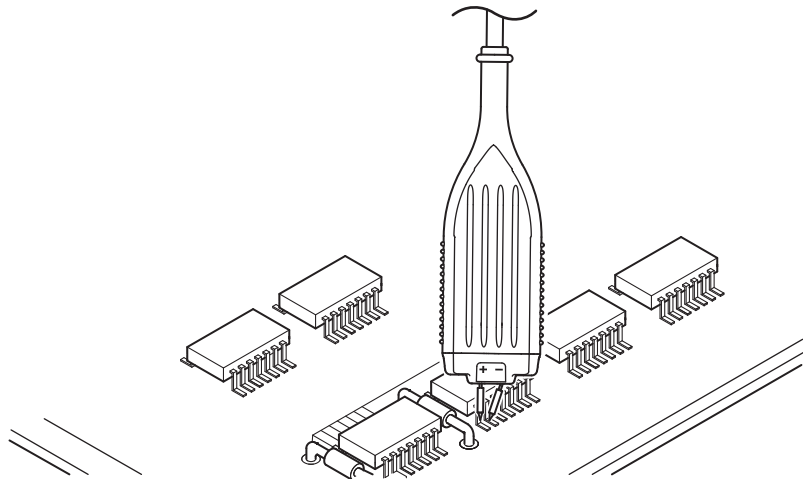

Warm-up and Offset Adjustment

Warm-up

Immediately after connecting the probe, the heat emitted by the probe itself causes the offset voltage to drift. Warm up the probe for at least 30 minutes after applying power to stabilize the probe.

Offset Adjustment

You can turn the offset voltage adjustment variable resistor on the probe interface by using an appropriate adjustment driver (see page 2 for details) to adjust the residual offset voltage that remains even after warm-up.

CAUTION

Do not turn the variable resistor with excessive force when adjusting the offset voltage. Doing so may break the variable resistor.

Note

- The offset voltage drifts depending on the ambient temperature. Pay attention to changes in the ambient temperature when making continuous measurements.
 - Only use the offset voltage adjustment variable resistor to adjust the residual offset voltage. If you deliberately change the offset voltage for some other purpose, the probe may no longer meet the specifications.
-

Product Specifications

Electrical Specifications

(The electrical specifications are based on standard operating environment after 30-minute warm-up.)

Frequency bandwidth	DC to 1 GHz (–3 dB or higher)
Attenuation ratio and DC voltage accuracy* ¹	50:1, within ±2% of the differential input voltage* ² (into 50-Ω load, excluding oscilloscope errors. See appendix 2.)
Input capacitance	Approx. 1.1 pF (relative to ground, typical value* ⁵)
Input resistance	Within 1 MΩ ± 3% (relative to ground)
Output impedance	Approx. 50 Ω (typical value* ⁵)
Maximum operating input voltage range	±35 V (DC + ACpeak)
Maximum differential input voltage range	±25 V (DC + ACpeak)
Maximum non-destructive input voltage* ³	±100 V (instantaneous)
Maximum non-destructive continuous input voltage	±35 V (DC + ACpeak)
Rise time	350 ps or less (excluding characteristics of the oscilloscope, typical value* ⁵)
Residual noise	500 μVrms or less (at the probe output, typical value* ⁵)
Residual offset* ⁴	Within ±10 mV (after adjustment)
Common mode rejection ratio	DC to 1 MHz: –35 dB or less 1 MHz to 10 MHz: –30 dB or less 10 MHz to 100 MHz: –26 dB or less 100 MHz to 300 MHz: –20 dB or less

*¹ Excludes residual offset voltage.

*² Under standard operating environment (23°C ± 5°C).

*³ Maximum instantaneous voltage that will not break the probe. It is not the rated voltage that you can use continuously. For continuous usage, use it within the maximum operating input voltage range.

*⁴ When 0 V is applied to both positive and negative input terminals.

*⁵ Typical values represent typical or average values. They are not strictly warranted.

Derating of the input voltage by frequency

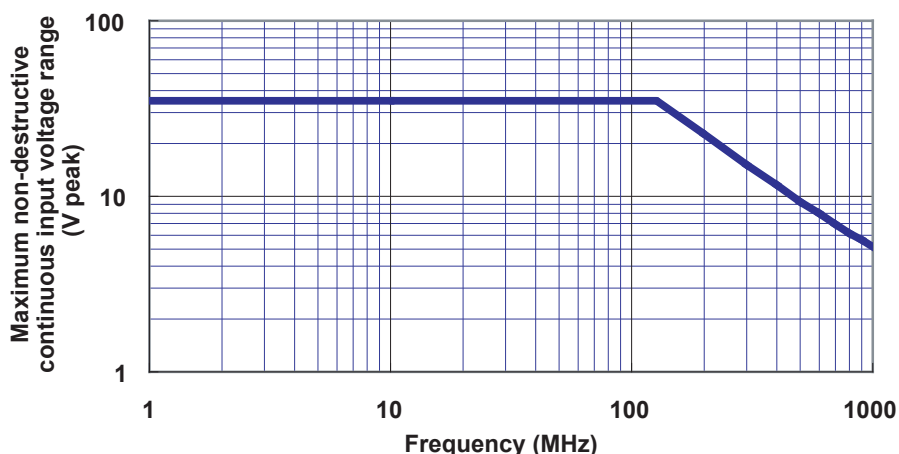

Input voltage range

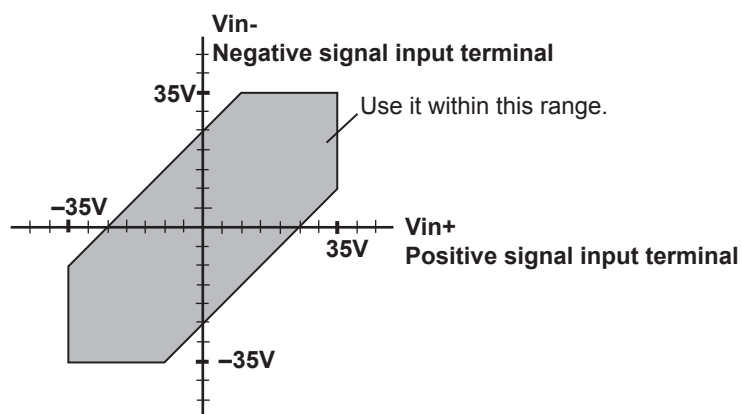

General Specifications

Supply voltage range Interface	Standard supply voltage $\pm 5V$, within $\pm 5\%$ (Power is supplied to the probe through a dedicated terminal. Connect the probe to a digital oscilloscope with a compatible terminal.)
Storage altitude	3000 m or less
Operating altitude	2000 m or less
Standard operating environment	Temperature range $23 \pm 5^\circ C$ Humidity range* ⁶ $55 \pm 10\%RH$
Operating environment	Temperature range 5 to $40^\circ C$ Humidity range* ⁶ 20 to $80\%RH$
Storage environment	Temperature range -20 to $60^\circ C$ Humidity range* ⁶ 20 to $80\%RH$
Calibration period	1 year
Warm-up time	At least 30 minutes
Total length	Approx. 1.2 m
Weight	Approx. 90 g

Standards Compliance

EMC	Emission	Complying standard	EN61326-1 Class A EN55011 Class A, Group1 C-tick EN55011 Class A, Group1
	Immunity	Complying standard	EN61326-1 Table 2 (for use in industrial locations)
		Influence in immunity test environment	$ Noise\ increase \leq 2\ V^{*6}$

*⁶ No condensation.

*⁷ Test conditions

Frequency bandwidth limit 20 MHz, using a DL9000 series digital oscilloscope with the input impedance set to $50\ \Omega$, and both plus and minus probe tip inputs connected (terminated) to $50\ \Omega$.

Appendix 1

Frequency Characteristics of Each Attachment

The probe's frequency characteristics vary depending on the attachment that is used and how the lead wires are connected. The frequency characteristics when using a typical attachment are given below.

The frequency characteristics for the case when pair leads or pair leads and micro clips are used have been measured with the two lead wires connected in a parallel manner.

When using a straight pin

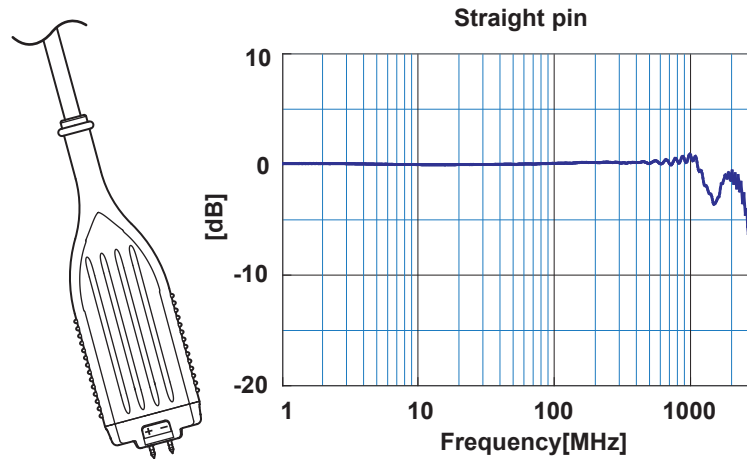

When using a spring-type angle pin

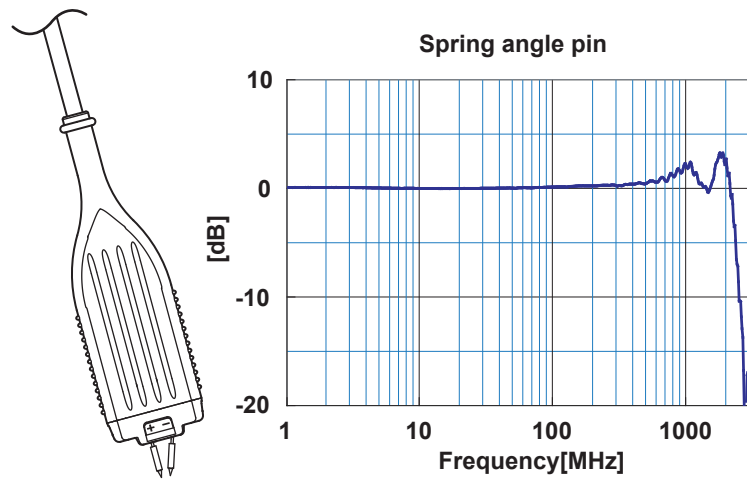

When using a 5-cm pair lead

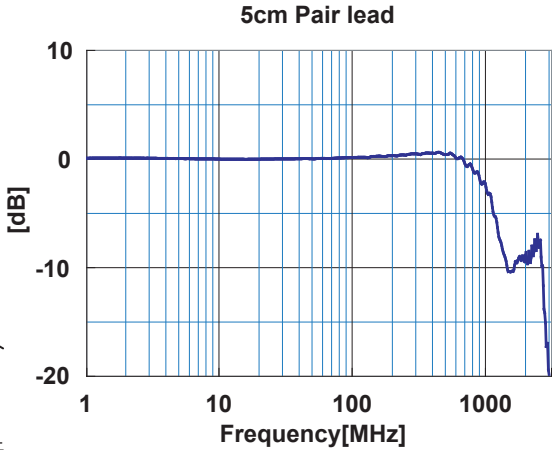
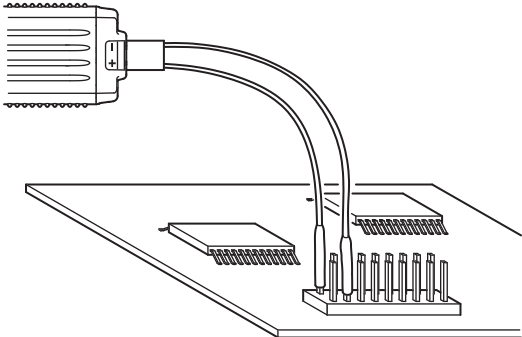

When using a 5-cm pair lead with micro clip

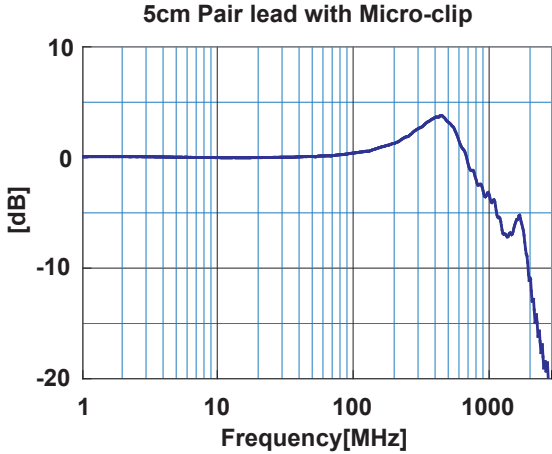
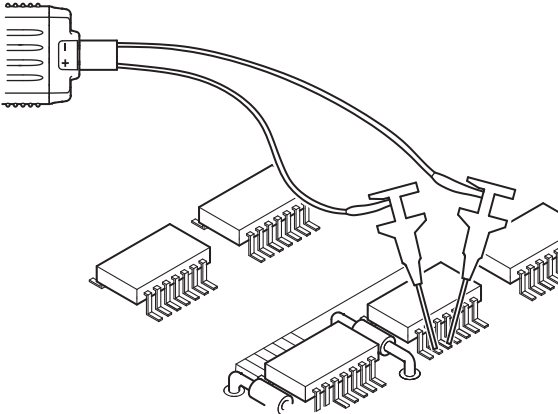

When using a 10-cm pair lead

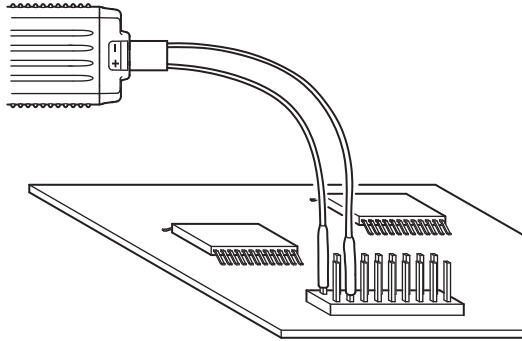

10cm Pair lead

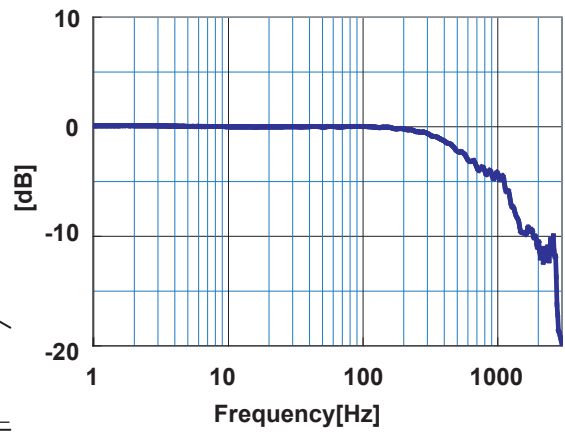

When using a 10-cm pair lead with micro clip

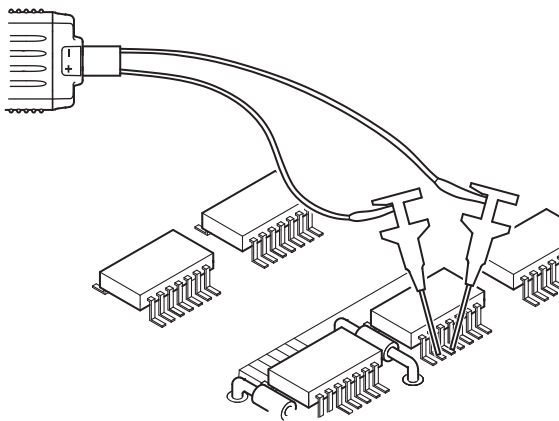

10cm Pair lead with Micro-clip

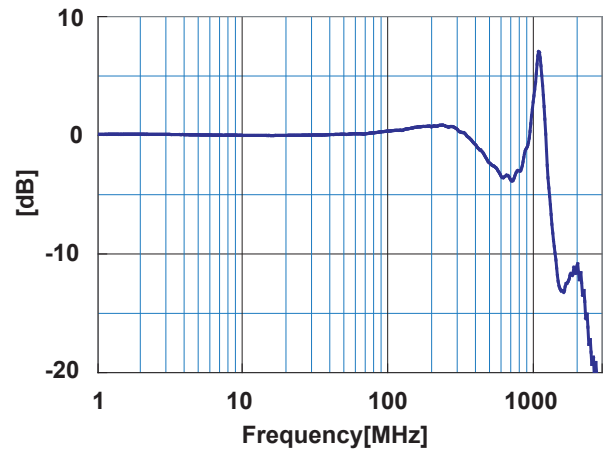

Appendix 2 Input Equivalent Circuit and DC Voltage Accuracy

Input equivalent circuit

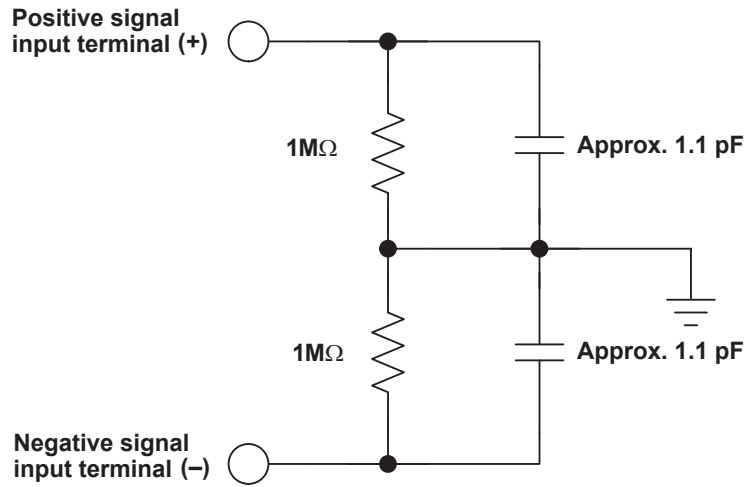

Conceptualization of DC Voltage Accuracy

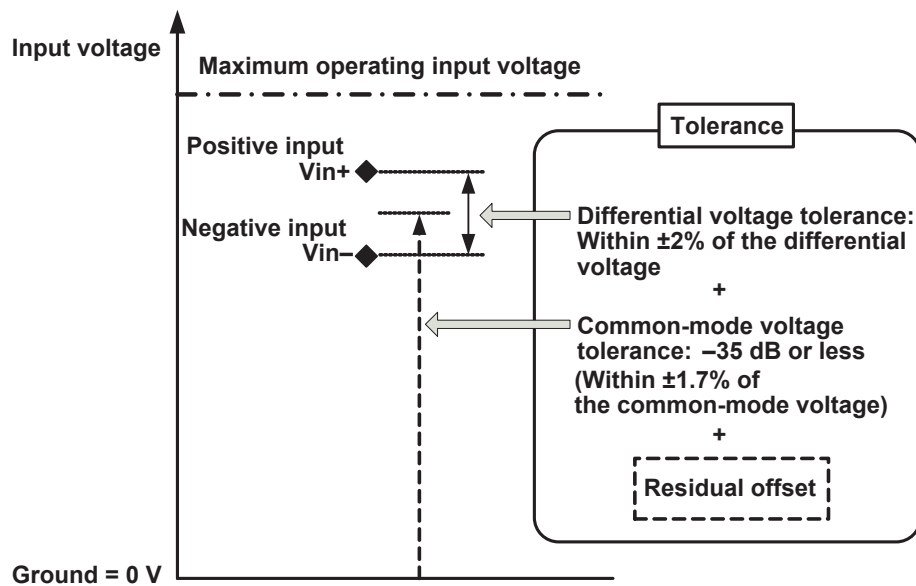

Appendix 3 **Probing**

The speed of devices and electronic circuits that are incorporated into a variety of products, as exemplified by digital home electronics, is increasing, and oscilloscopes and probes used to observe their signal waveforms are also faster and have wider bandwidths.

When the speed of the measured signal increases, there are cases when correct measurements cannot be taken due to problems that have never occurred before, especially in probing. This chapter explains issues that need to be considered when probing high-speed signals.

Voltage Probe Types

A Voltage probes is a type of voltage sensor. The ideal probe should be selected according to the signal's voltage, output impedance, frequency components, and other factors. The input impedance (resistance and capacitance) and frequency can differ greatly depending on the type of probe. So, it is essential to understand the characteristics of the available probes to obtain highly reliable measurements. Below are three examples of probes generally used for measurements on high-frequency circuits.

Passive Probes

Passive probes with a 10:1 attenuation ratio are the most widely used due to their low cost, ruggedness, high withstand voltage, and high input impedance at DC and low frequencies.

Yokogawa's standard 10:1 passive probes are easy-to-use for general applications. Their input impedance is 10 M Ω and approximately 14 pF in parallel, and the withstand voltage is 600 V. However, the 14 pF input capacitance might cause problems when high frequencies are measured.

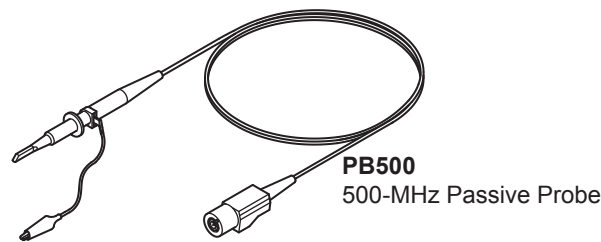

Active Probes and FET Probes

Active and FET probes are those most often used to measure high frequency signals.

Unlike passive probes, an impedance-converting buffer amplifier is situated near the tip of the probe which enables them to handle higher frequencies with around 1-pF input capacitance. They are very effective in terms of reliability and their ability to reproduce high frequency signal waveforms. They require a power supply and must be handled with more care than a passive probe, because the with-stand voltage is lower.

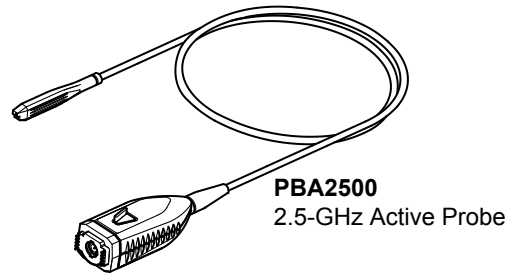

Low Capacitance Probes (Low Impedance Probe)

These probes are not so well known, but they have been used with measuring instruments having 50 Ω inputs for a relatively long time.

The probe head has a special built-in 450- Ω or 950- Ω resistor, designed for high frequency, and uses a 50- Ω coaxial cable. It is still very popular to this day, because the input capacitance is extremely small.

This probe is ideal for high quality measurement of clock edges or other high speed digital signal waveforms as the input capacitance is half, or even a small fraction, of that of the active probe. However, because the input resistance is 500 Ω or 1 k Ω , it can have an affect on the DC bias or output amplitude if the impedance of the signal source being measured is high.

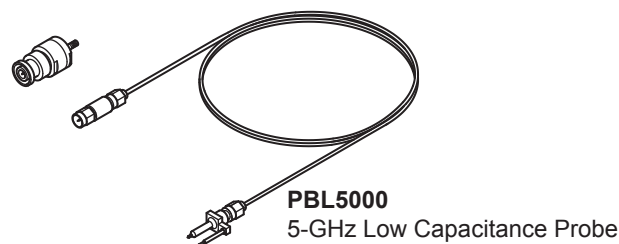

Problems with Probing High-Speed Signals

Loading Effect

When a probe is connected to the circuit under test, the input impedance of the probe itself has certain effects on the circuit. This is called the *loading effect*. There can be cases where there are notable low pass filter effects caused by the signal source impedance and the probe's load capacitance, particularly when observing frequency components of 100 MHz or more.

Let us take an example of a 50-Ω circuit shown below. In this example, the equivalent signal source impedance appears as 25 Ω (2 x 50 Ω in parallel) when observing the signal waveform at the load (terminal). The cutoff frequency at the probe's input point is $f_c = 1/2\pi RC$, if the probe input capacitance is added. When using a 14-pF input capacitance passive probe, f_c equals 455 MHz, but when a 0.9-pF input capacitance active probe is used, f_c equals 7 GHz.

We recommend that you use an active or FET probe with a smaller input capacitance, because even more pronounced loading effects will emerge when measuring a circuit with a high-output impedance.

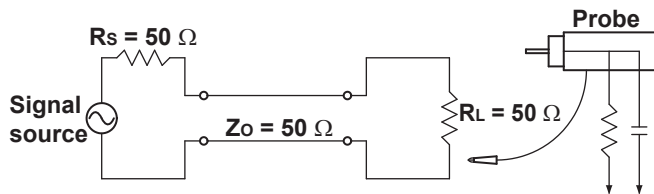

Resonance due to Inductance

Pins or wires of some sort are used to connect the probe to the circuit under test. Inductance occurs when these pins or wires reach certain lengths, which results in resonance with the probe's input capacitance. This will not obscure observation of the waveform if these resonant frequencies are outside of the oscilloscope's frequency bandwidth. However, overshooting or ringing, which was not originally present, will be introduced into the signal waveform being observed if the inductance or capacitance is large.

The resonant frequency is surprisingly low when the resonant frequencies of three different types of probes are compared as in Figure 1 with a given connected inductance of 10 nH (a length of up to 1 to 2 cm). You must be aware that effects of this inductance can be found not only on the probe input, but also in the ground connection.

	PB500 Passive Probe	PBA2500 Active Probe	PBL5000 Low Capacitance Probe
Input impedance	Approx. 14 pF	Approx. 0.9 pF	Approx. 0.25 pF or 0.4 pF
Resonant frequency (When L = 10 nH)	425 MHz	1.68 GHz	3.18 GHz

Changes in Cable Characteristics

A coaxial cable is used to transfer signals from the probe tip to the oscilloscope. Cables that can offer the right balance of both flexibility and high frequency performance are selected after considering the ways in which the cables will actually be handled. Even so, if a cable is bent sharply, the dielectric can break, altering the characteristic impedance and subsequently weakening the cable's throughput and reflectivity. This in turn will affect the high frequency components of the observed waveform.

This is one of the causes of poor repeatability in the observation of high frequency waveforms. The repeatability can be increased by bending the cables as little as possible in a uniform manner.

Getting the Best Performance Out of Your Probe

When using probes, inductance-based resonance is the biggest problem during waveform measurement, and it is most important to suppress it.

Make the probe's input pins and ground lead as short as possible when the goal is to easily check signals (browsing). When highly reliable waveform observation is called for, prepare a thru-hole PCB for connecting the probe and directly connect the probe's signal input pins onto the PCB trace or to another fitting (No. 1 and No. 2). Connect the probe to a prepared copper wire or plate that is as thick as possible to reduce inductance in the ground.

If it is not possible to connect a short wire, you can insert a 50 to 100- Ω resistor to dampen the resonance (No. 3). In this case, the measurable frequency bandwidth is reduced by the resistance, but you can approximate the original waveform more closely by suppressing the resonance effects of overshooting and ringing.

Also, try securing the cable to the workbench with tape so that the bends in the cable do not change (see the next page), because high frequency signal components are, as stated above, affected by cable bending. This may improve the repeatability of the observed waveform.

Probing Methods

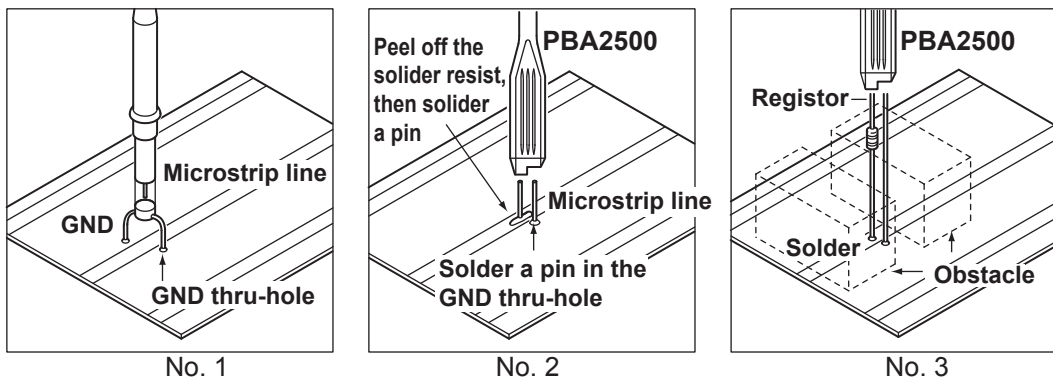

Ringing Comparison

When inductance is large and ringing can be seen

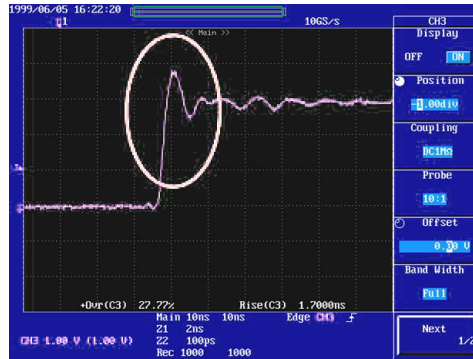

When inductance is reduced and ringing is suppressed

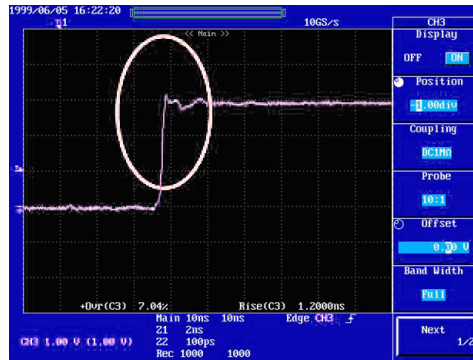

Probe Cable Bending

